

13
Glorious Years
in Material Handling



**Manual
Stacker
1000 Kg.**

**Hand
Pallet Truck
2500 Kg.**



**M.D. ENGINEERING
M.D. INDUSTRIES**

Hand Pallet Truck (MDI 25)

- Most standard and popular model with 2500 kg. capacity
- Supporting base: the new type is thicker in case of bending problems.
- Forks: the thickness of the new type is 53mm to increase strength
- Great innovation on the part of wheel frame:
 - A. The new type wheel frame enhances strength to prevent distortion problems
 - B. The new type frame without roll ring & roll sheath
 - C. Adopts double-spring pins construction with strengthened ribbing under triangle to prevent pin snipping problems
- With Copping Supporting NOG & strengthened ribbing under top triangle cover
- Complete pump design with reliable leak-proof pump to eliminate maintenance and extended the service time
- 210 steering arc and small turning radius
- Fork lowering speed is controllable; operated by hand control and foot pedal
- Ergonomic rubber wrapped handle, which is comfortable and convenient to operate
- Entry / exit roller, for more free transport
- Equipped with over-load valve, with long service time
- 3 position hand control - Raise, Lower, Neutral
- 12 lubrication grease nipples on all movable parts for easy maintenance
- Adjustable pump cap ensures a long service life Ergonomic large rubber handle with three control lever
- **Option:**
 1. C I Wheel, Polyurethane Wheel or Rubber Wheel Standard Pallet Trucks are supplied with Nylon Wheel
 2. Single Fork Roller or Tandem Fork Rollers
 3. Fork length: 800 mm, 900 mm, 1000 mm

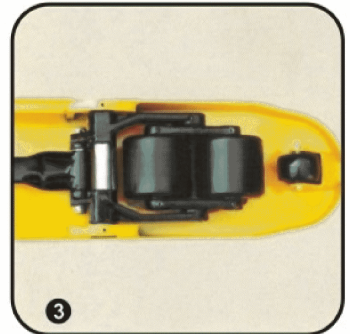
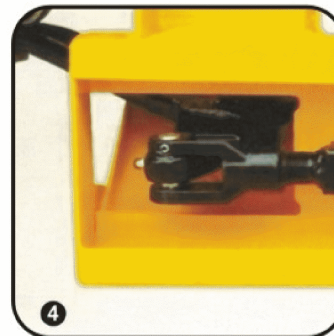

- 1 Adjustable pump cap with thicker supporting base and foot pedal release.
- 2 Rubber wrapped handle
- 3 Entry roller for easy operation and innovative wheel frame
- 4 Adjustable straight tapet

MODEL		MDI 25
Lowered Fork Height	h13 (mm)	90
Steering Wheels	mm	200
Support wheel	mm	180x50
Fork wheel tandem	mm	82x70
Max. lift height	h3 (mm)	200
Total height	h14 (mm)	1224
Overall length	11 (mm)	1533
Fork length	1 (mm)	1150
Width overall forks	b5 (mm)	550/685
Ground clearance, center of wheelbase	m2 (mm)	32
Aisle width for pallets 1000 X 1200 crossways	Ast (mm)	1733
Aisle width for pallets 800 X 1200 crossways	Ast (mm)	1783
Turning radius	Wa (mm)	1266
Service weight	kg	65-80

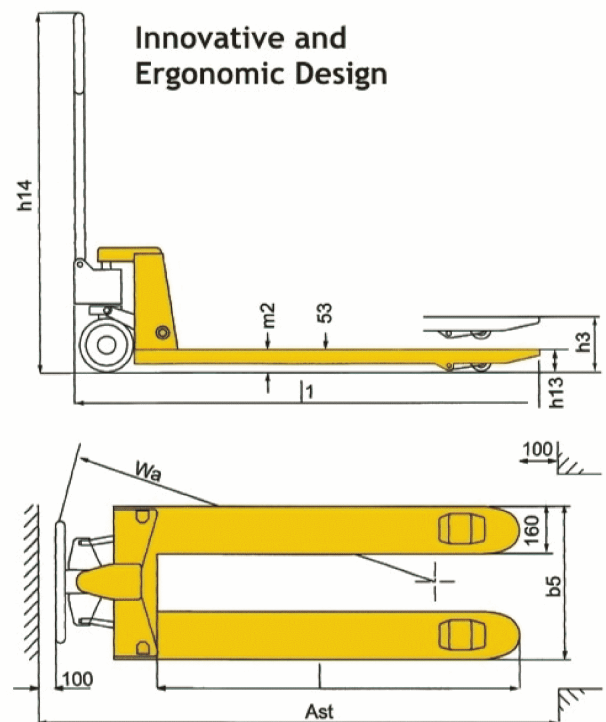

Special size, width and length can be made according to customer's requirement.

Warranty : 18 months